

## 32 inch Panel PC ARCHMI-932BP



- 32" TFT LCD, 1920 x 1080 pixels
- Projected capacitive touch
- Processor: Intel® Core™ i3-8145UE (3.9 GHz) / i5-8365UE (4.1 GHz)
- Fanless cooling system
- Reading angle horizontal 178°, vertical 178°

<https://www.wachendorff-prozesstechnik.de/en/ARCHMI-932BP>

### Description

The ARCHMI-9B series is based on an 8th generation Intel® Core™-i processor.

This very powerful and efficient processor family provides sufficient computing power for medium and large applications. The RAM can be expanded to up to 32 GB, enabling more extensive projects such as SCADA or IIoT monitor control applications. The Panel PCs in this series are available in display sizes ranging from 12.1" to 32" and can be equipped with projected capacitive, resistive or no touch. The projected capacitive touch enables multi-touch operation with a corresponding operating system. If pressure-sensitive operation is required (e.g. with gloves), the resistive touch is the right choice. The front panels are absolutely flush with the die-cast aluminum housing. The housing is IP66 rated. The unique fanless thermal design of the die-cast aluminum housing enables effective temperature control. The ARCHMI IPC can be optionally equipped with a high-brightness LCD and/or optical bonding for an outstanding display, even under difficult conditions. Expansion cards for additional interfaces or WLAN can also be integrated.

### Product details

Power supply:	9 VDC to 36 VDC
Power consumption:	max. 80 W
Display:	32" TFT LCD
Resolution:	1920 x 1080 pixels
Aspect ratio:	16:9
Brightness:	500 cd/m <sup>2</sup>
Colors:	16.7 million
Reading angle:	H: 178° / V: 178° H: 178° / V: 178° (optional 1024 x 768 pixels) H: 178° / V: 178° (optional high-brightness LCD) H: 178° / V: 178° (optional high-brightness LCD with 1024 x 768 pixels)
Touch screen:	Projected capacitive touch
Processor:	Intel® Core™ i3-8145UE (3.9 GHz) Intel® Core™ i5-8365UE (4.1 GHz)
RAM:	up to 32 GB DDR4 2400 MHz SO-DIMM
SSD/HDD:	1x M.2 SSD M-Key (standard 128 GB TLC SSD/M.2)

Interfaces:	USB: 2 x USB 3.0 type A Serial: COM1: RS232 / RS422 / RS485; COM2: RS232 Ethernet: 2x GbE 10/100/1000 Base T (X), RJ45 Audio: 3.5 mm jack Video: 1 x DP Power supply: pluggable 3-pin terminal strip On/off switch: optional plug-in 2-pin terminal strip, see accessories IPC_DIO_2P
Expansion slots	1 x Mini PCIe full height (internal)
Housing:	Die-cast aluminum
Assembly:	VESA 200 x 200; panel mounting
Protection class:	IP66 on the front
Dimensions (WxHxD):	810 mm x 490 mm x 65 mm
Weight:	approx. 17.4 kg
Ambient conditions:	Operation: 0 °C to +50 °C ; Storage: -30 °C to +70 °C 10% to 90 %rH, non-condensing.
Certifications:	CE/FCC Class A
Operating systems:	Windows® 10 IoT Windows® 11 IoT Linux

Options:	<p>VGA HDMI</p> <p>4 x USB 2.0 2 x USB 2.0 + 1 x COM (RS-232) 2 x USB 2.0 + 1 x COM (RS-232) + 1 x power button 2 x USB 2.0 + 1 x COM (RS-232) + 1 x power button + 1 x Mini PCIe + 1 x SIM card slot 2 x USB 2.0 + 1 x Mini PCIe + 1 x SIM card slot 2 x USB 2.0 + 1 x LAN 2 x USB 2.0 + 2 x CAN + 1 x Mini-PCIe + 1 x SIM card slot 2 x COM (RS-232) 2 x COM (RS-232) + 1 x Mini-PCIe + 1 x SIM card slot 2 x COM (RS-232/RS-485, isolated)</p> <p>WLAN 2.4GHz, BT4 WLAN 2.4GHz, 5GHz, BT4</p> <p>Optical bonding Smart battery</p>
Scope of delivery:	<p>Device 1 x power supply unit 1 x mounting material</p>
Customs tariff number:	84715000
Manufacturer:	Aplex Technology Inc.

#### Products Order no.

ARCHMI-932BP	32" industrial panel PC, projected capacitive touch
--------------	---

#### Accessories Order no.

ETHSWG5C	5-way Ethernet switch, Gigabit, unmanaged
ETHSWG8C1	8-port Ethernet switch, Gigabit, unmanaged
KABETH10	Patch cable, RJ45 UTP CCA, CAT5e white, 0.3 m
KABETH11	Patch cable, RJ45 UTP CCA, CAT5e white, 1 m
KABETH12	Patch cable, RJ45 UTP CCA, CAT5e white, 2 m
IPC_DIO_2P	2-pin connector plug, digital input

**Drawings**

Dimensions 01 (mm):

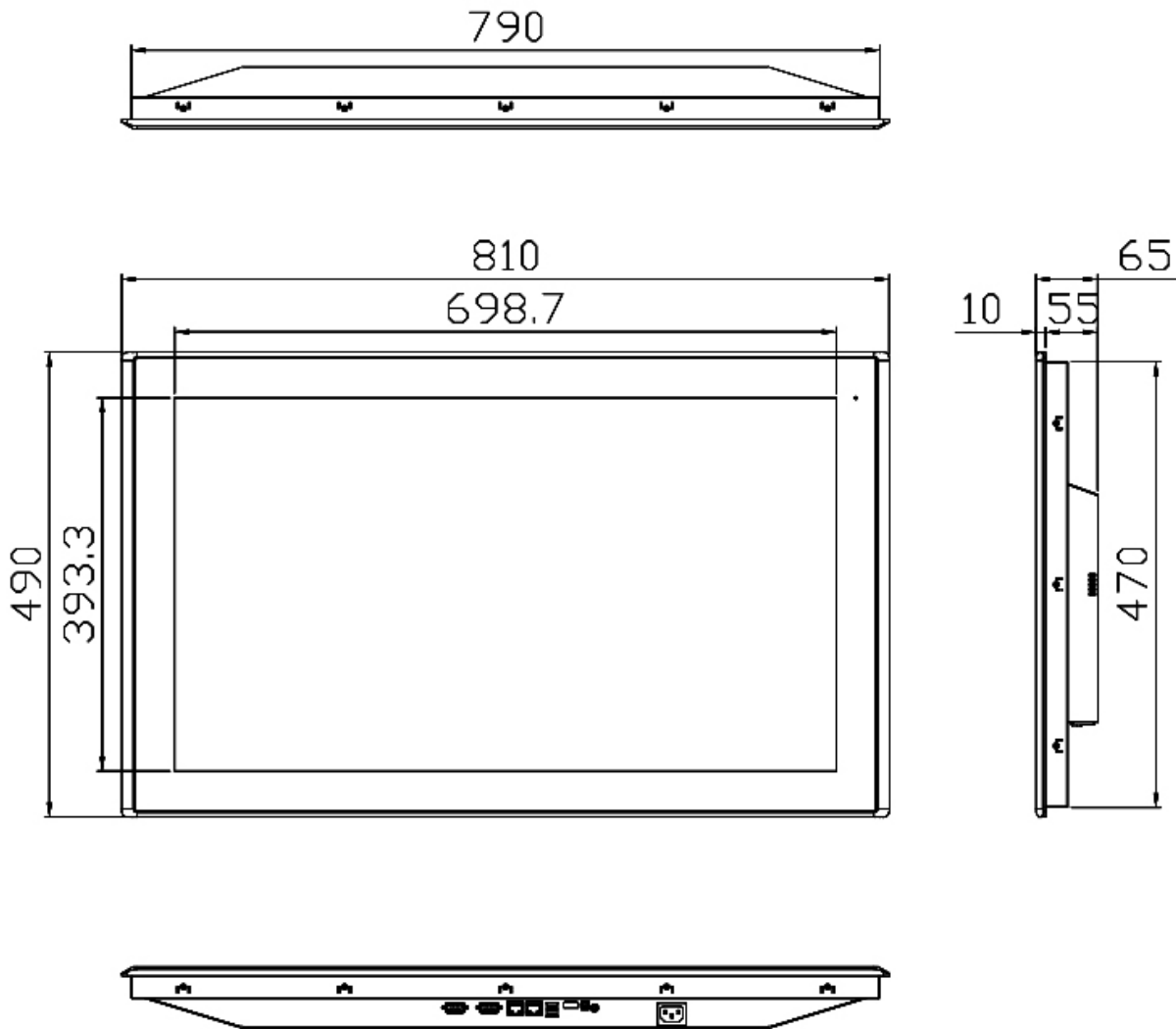

UNIT: mm  
Tolerance:  $\pm 0.5$

**Downloads / FAQ**

The following files could be downloaded from our website directly from this product under the tab "Drawings":

**2D drawing Panel PC ARCHMI-912**

Panel-PC-ARCHMI-X12.dwg

**Drawings**

**Dimensions 02 (mm):**

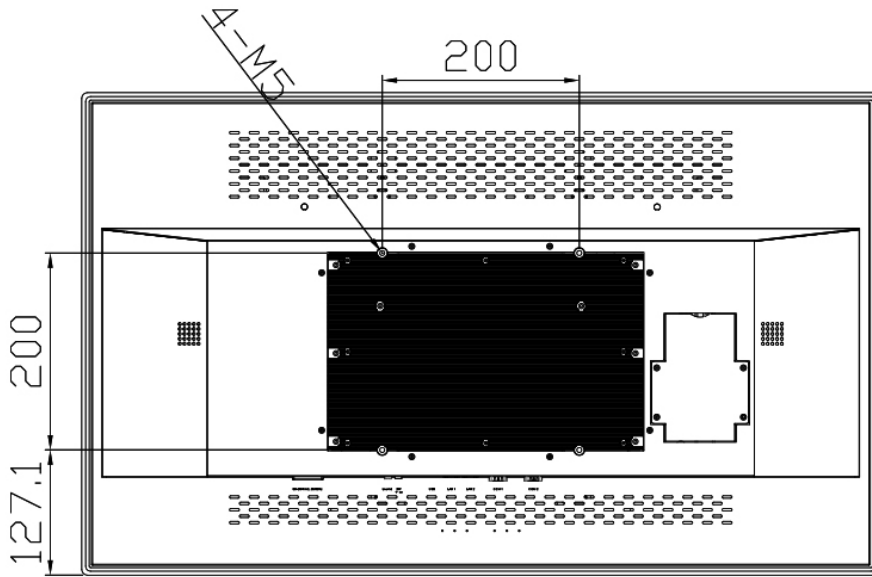

Panel-PC-ARCHMI-X12.dwg



Wachendorff Prozesstechnik GmbH & Co. KG  
Industriestrasse 7 • 65366 Geisenheim  
Germany

Phone: +49 (0) 67 22 / 99 65 - 20  
E-Mail: [wp@wachendorff.de](mailto:wp@wachendorff.de)  
[www.wachendorff-prozesstechnik.de](http://www.wachendorff-prozesstechnik.de)

