

17 inch Panel PC ARCHMI-817BP



- 17" TFT-LCD, 1280 x 1024 pixels
- Projected capacitive touch
- Processor: Intel® Celeron® J6412 (2.0 GHz, 1.5MB L2 cache)
- Fanless cooling system
- Reading angle: Standard: 170(H) / 160(V), optional high brightness: 140(H) / 140(V)

<https://www.wachendorff-prozesstechnik.de/en/ARCHMI-817BP>

Description

The ARCHMI-8B series is based on an Intel® Celeron® J6412 processor with 2.0 GHz.

The industrial panel PCs in this series are available in display sizes from 7" to 23.8", with either projected capacitive or resistive touch. The projected capacitive touch enables multi-touch operation with a corresponding operating system. If pressure-sensitive operation is required (e.g. with gloves), the resistive touch is the right choice. The front panels are absolutely flush with the die-cast aluminum housing. The front of the housing is IP66 rated. The unique fanless thermal design of the die-cast aluminum housing enables effective temperature control. The ARCHMI-IPC can be optionally equipped with a high brightness LCD and/or optical bonding for an outstanding display, even under difficult conditions. This high-performance yet highly energy-efficient processor family is used, for example, in factory automation, remote data acquisition and in the most common industrial applications.

Product details

Power supply:	9 VDC to 36 VDC
Power consumption:	46 W
Display:	17" TFT LCD
Resolution:	1280 x 1024 pixels
Aspect ratio:	5:4
Brightness:	350 cd/m ² 1000 cd/m ² (optional high-brightness LCD)
Backlight:	30,000 h runtime 50,000 h runtime (optional high-brightness LCD)
Colors:	16,2 M 16.7 M (optional high-brightness LCD)
Reading angle:	H: 170° / V: 160° H: 140° / V: 140° (optional high-brightness LCD)
Touch screen:	Projected capacitive touch
Processor:	Intel Celeron J6412 Processor (2.0 GHz, 1.5MB L2 cache)
RAM:	1 x 260-pin SO-DIMM up to 32GB DDR4 3200MHz
SSD/HDD:	1 x M.2 B-Key slot; (Support SATA3; 2242/2280)

Interfaces:	USB: 2 x USB 3.2 Gen2 type A / 2x USB 2.0 type A Serial: COM1: RS232 / RS422 / RS485 Ethernet: 2x 2.5 GbE, RJ45 Audio: Audio output Power supply: 1 x 3-pin terminal strip, 1 x 2-pin power switch connection
Expansion slots	1 x Mini PCIe slot 1 x M.2 E-key 1 x Nano SIM card slot
Housing:	Die-cast aluminum
Assembly:	VESA 100 x 100; panel mounting
Protection class:	IP66 on the front
Dimensions (WxHxD):	439 mm x 348 mm x 64.8 mm
Weight:	6.07 Kg
Ambient conditions:	Operation: 0 °C to +50 °C (optionally -20 °C to +60 °C) Storage: -30 °C to +70 °C 10% to 95 %rH, non-condensing.
Certifications:	CE/FCC Class B/UL
Operating systems:	Windows® 10 IoT Windows® 11 IoT

Options:	<p>Extended temperature range -20 °C to +60 °C VESA mount</p> <p>4G LTE / WLAN (Wi-Fi 4/5/6+) / Bluetooth 4 x USB 2.0 type A (TB-528U4) 4 x USB 2.0 type A + 1 x mini PCIe + 1 x SIM card slot (TB-528U4ME1) 2 x COM (RS-232) (TB-528C2) 1 x COM (RS-232) + 2 x USB 2.0 (TB-528C1U2) 1 x COM (RS-232) + 2 x USB 2.0 + 1 x on/off switch (TB-528C1U2P1) 2 x COM (RS-232) + 1 x Mini PCIe slot + 1 x SIM card slot (TB-528C2ME1) 2 x COM (RS-422/485, galvanically isolated) (TB-528C2I) 2 x CAN (TB-528CAN2) 1 x LAN + 2 x USB 2.0 type A (TB-528E1U2) 1 x 2-watt loudspeaker 1 x Automatic brightness adjustment 1 x backup battery 21 W / 10.8 V / 1.95 Ah (3S1P)</p>
Scope of delivery:	<p>Device 1 x power supply unit 1 x mounting material</p>
Customs tariff number:	84715000
Manufacturer:	Aplex Technology Inc.

Products Order no.

ARCHMI-S-817BP	17" industrial panel PC, projected capacitive touch
----------------	---

Accessories Order no.

ETHSWG5C	5-way Ethernet switch, Gigabit, unmanaged
ETHSWG8C1	8-port Ethernet switch, Gigabit, unmanaged
KABETH10	Patch cable, RJ45 UTP CCA, CAT5e white, 0.3 m
KABETH11	Patch cable, RJ45 UTP CCA, CAT5e white, 1 m
KABETH12	Patch cable, RJ45 UTP CCA, CAT5e white, 2 m
IPC_DIO_2P	2-pin connector plug, digital input

Drawings

Dimensions (mm) and STEP file/viewer:

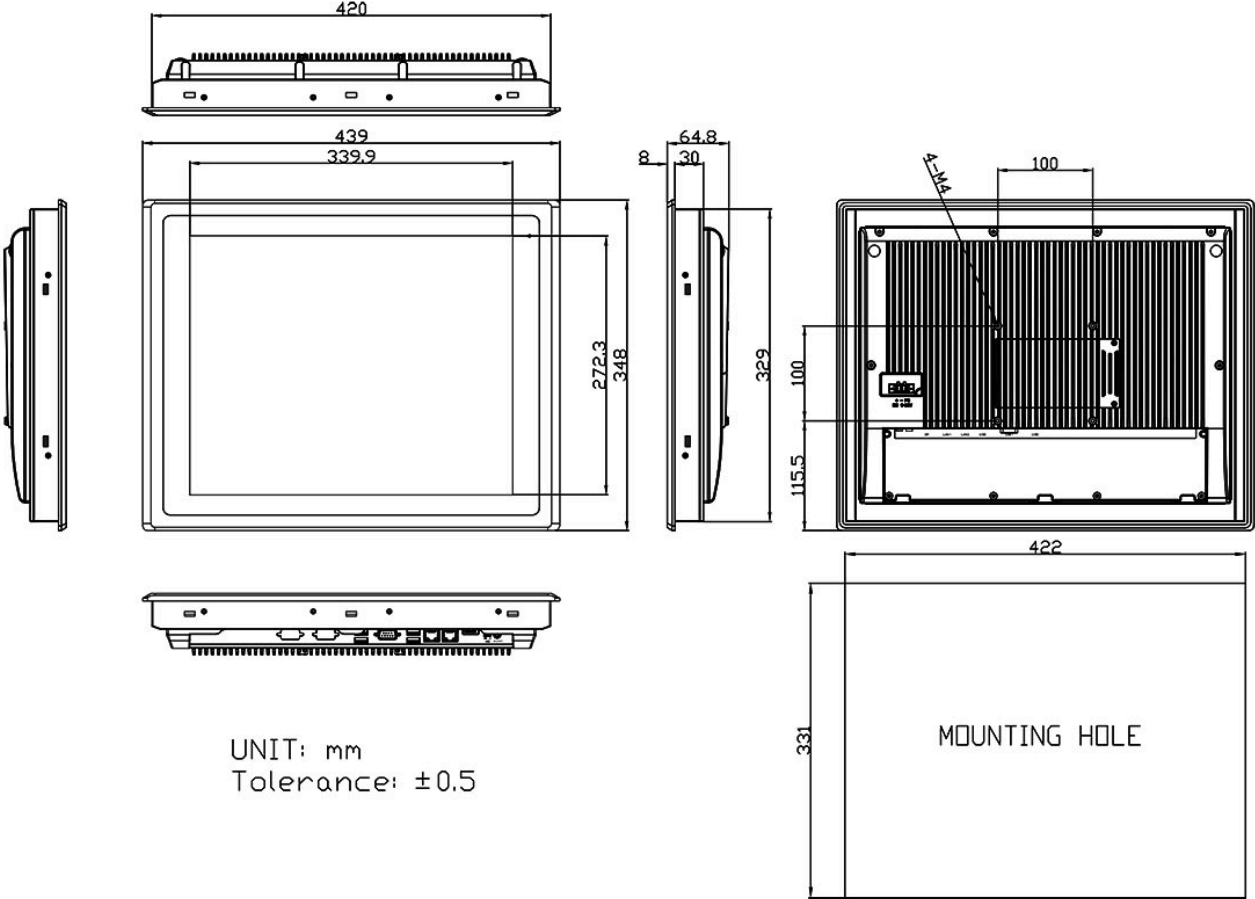



Wachendorff Prozesstechnik GmbH & Co. KG
Industriestrasse 7 • 65366 Geisenheim
Germany

Phone: +49 (0) 67 22 / 99 65 - 20
E-Mail: wp@wachendorff.de
www.wachendorff-prozesstechnik.de

