

Frontless HMI cMT-SVR-200/202



- Supports display on cMT Viewer clients.
- Compact design and DIN rail mounting
- Fanless cooling system
- Integrated 256 MB flash memory
- microSD card slot for memory expansion
- USB host port
- E-mail
- Supports MPI 187.5K
- WiFi compatible with 802.11 b/g/n

<https://www.wachendorff-prozesstechnik.de/en/cmt-svr-200-202>

Description

With Weintek's frontless HMI cMT-SVR-200/202, the architecture of a classic operating device is divided into a display unit and a communication unit. The display is shown via an app over Wi-Fi on an iPad or Android tablet (ARM or x86) or alternatively via a wired connection over Gigabit Ethernet on suitable displays or Windows-based panel PCs. The WLAN connection allows for a large range of motion and thus particularly flexible, mobile operation. Thanks to the separation of display and communication with the control system, performance is significantly increased, as the cMT-SVR-200/202 does not have to process image data itself; this task is performed by the respective display devices. With its serial interfaces and integrated MPI interface, the cMT-SVR-200/202 is an ideal solution for mobile and brilliant visualizations. The cMT-SVR-200/202 from Weintek thus fulfills all the characteristics of a classic operating device and also enables mobile operation via up to three iPads and several wired displays.

Product details

Memory:	Flash: 256 MB RAM: 256 MB
Processor:	Quad-core RISC
Interfaces:	SD card slot: 1 x microSD USB Host: 1 x USB 2.0 USB Client: No Ethernet: 1 x 10/100 Base-T COM Port: COM1: RS232 2-wire, COM2: RS485 2-/4-wire, COM3 RS485 2-wire WiFi: IEEE 802.11 b/g/n, 802.11b: max. 19.52 dBm, 802.11g: max. 15.35 dBm, 802.11n: max. 15.28 dBm
Real-time clock:	Integrated real-time clock RTC
Power supply:	Input voltage: 24±20% VDC Galvanic isolation (input voltage from system voltage): integrated Current consumption: 450 mA at 24 VDC Dielectric strength: 500 VAC (1 min.) Insulation strength: >50 MOhm at 500 VDC
Specifications:	PCB Coating: Yes Housing: Plastic Dimensions (WxHxD): 27mm x 130mm x 115 mm Weight: approx. 0.18 kg

Ambient temperature:	Operating temperature: -20 °C to +55 °C. Storage temperature: -20 °C to +70 ° C. Relative humidity: 10 % to 90 % (non- condensing) Vibration resistance: 10 to 25 Hz, 2 g in X, Y and Z direction, 30 minutes each
Fastening:	35 mm top-hat rail mounting
Protection class:	IP20
Certificates:	CE UL-listed
Software:	EasyBuilder Pro from V6.02.02 Weincloud: cMT-SVR-200: EasyAccess 2.0 (optional) cMT-SVR-202: EasyAccess 2.0 (integrated)
Customs tariff number:	90328900
Manufacturer:	Weintek Labs, Inc

Products Order no.

cMT-SVR-200	Frontless HMI, EasyAccess 2.0 (optional)
cMT-SVR-202	Frontless HMI, EasyAccess 2.0 (integrated)

Accessories Order no.

cMT-IV6	9.7" touch panel for HMI server
WLANAP0C	WLAN Access Point Compact IEEE802.11 g/b Screw-on Demo Whip antenna 2 dBi included in the scope of delivery
ETHSW600	6-way Ethernet switch, unmanaged
ETHSWG8C1	8-port Ethernet switch, Gigabit, unmanaged
DRS4-24A	Power supply unit for DIN rail, 85 to 264 VAC, 24 VDC 4.2 A, screw terminal

Drawings

Dimensions and STEP data:

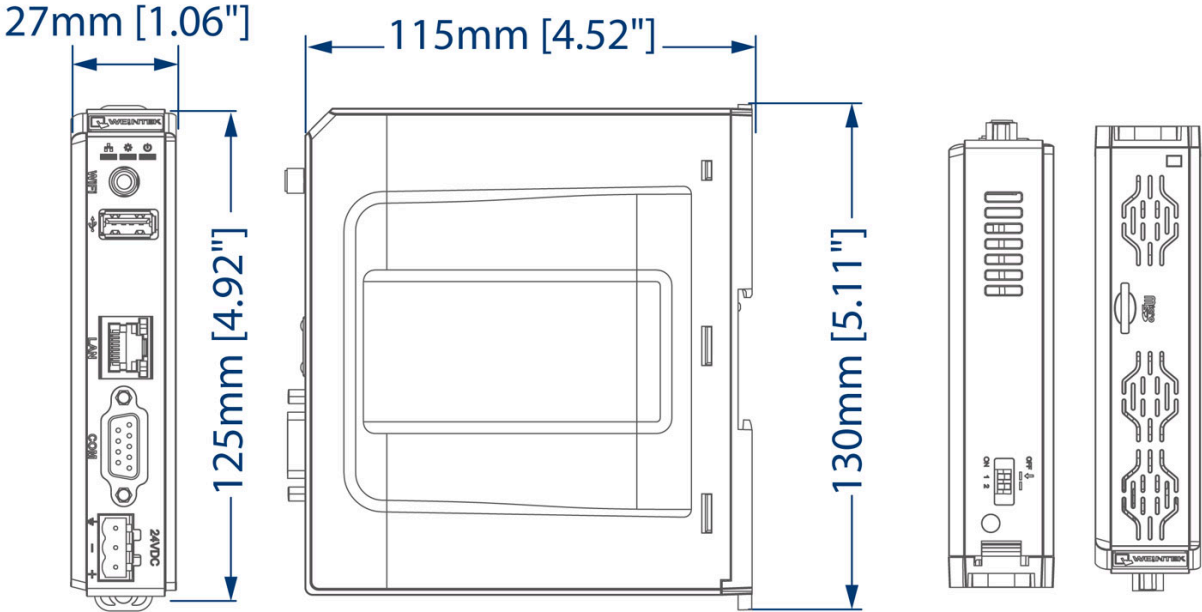



Wachendorff Prozesstechnik GmbH & Co. KG
Industriestrasse 7 • 65366 Geisenheim
Germany

Phone: +49 (0) 67 22 / 99 65 - 20
E-Mail: wp@wachendorff.de
www.wachendorff-prozesstechnik.de

